

EXPANDING CONVEYOR SYSTEM



TOP characteristics

- Reliable separation of products
- No refitting required when changing products
- Hygienically clean through closed surface
- Can be easily integrated in existing systems



Thanks to their closed, transverse elastic conveyor belt, our high-quality expanding conveyor systems can convey even miniature products or bulk materials. At the same time, this design allows any number of product series to be conveyed, and products to be quickly and easily changed.

Applications

- Separating and converging products
- Before coating plants
- Before packaging plants
- In "pick and place" systems

Technical specifications

- Belt support plate prevents belt sag
- Constant belt speed (up to 25 m/min)
- Conveyor belt made from silicone-coated polyester fabric
- Deflection diameter 76 mm
- Max. expansion range 30 %

Equipment

- With castors or machine feet
- Machine frame and chain cover from stainless steel 1.4301 (304)

Optional

- Variable belt speed through frequency converter
- Integrated transfer table for very small products

Operating temperature

- -10° C to +50° C





EXPANDING CONVEYOR SYSTEM – DIMENSIONS AND DETAILS

Dimensions (at 30 % expansion)

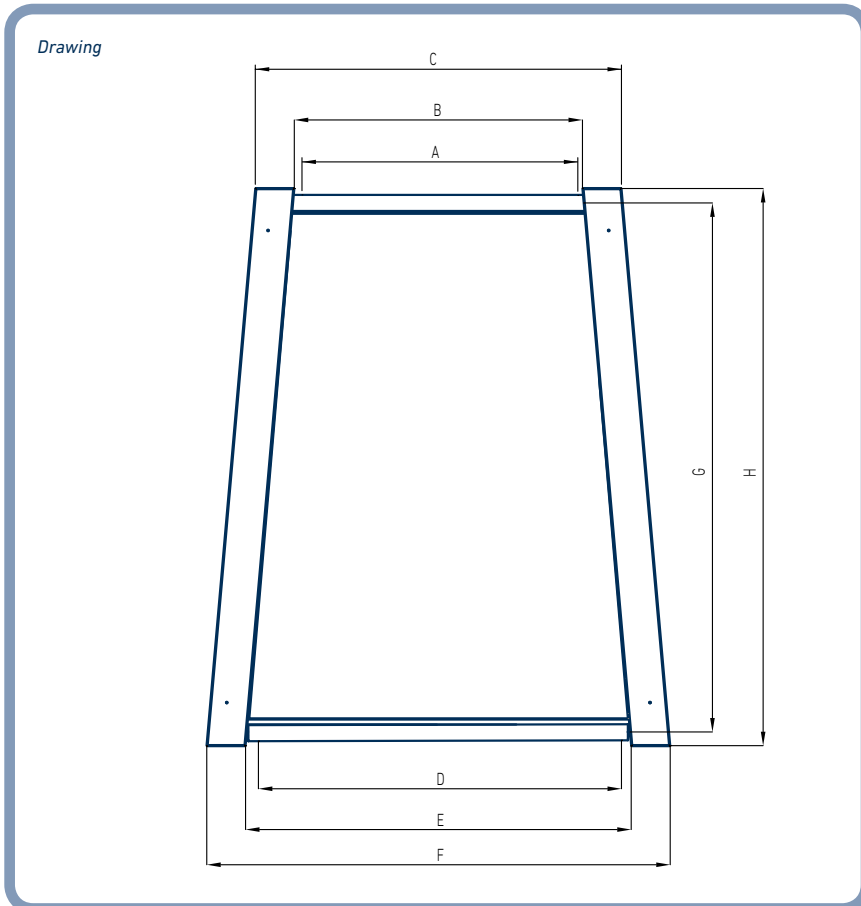

Special chain guide



Optimised belt change

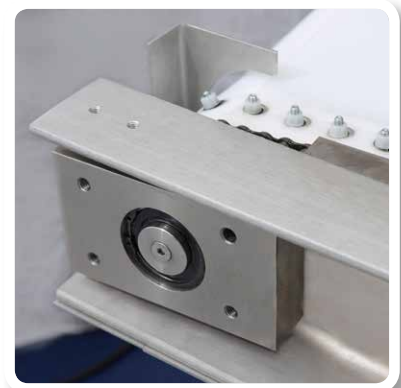

Maintenance-free bearings



Hygienic design

A (usable width)	B	C	D (usable width)	E	F	G	H
420	514	882	546	676	1080	915	1133
620	714	1082	806	936	1340	1258	1467
820	9140	1282	1066	1196	1600	1601	1819
1050	1144	1512	1365	1495	1899	1995	2213
1300	1394	1762	1690	1820	2224	2424	2642

All dimensions in mm.
Other dimensions also available on request.